

## Super-Slim Type Low-Noise Duct Fan (With Filter)

### 超薄型静音管道风机 (带过滤网)



The Super-Slim Type Low-Noise Duct Fan is an ideal equipment for ventilation in house, villas, office, conference rooms, shopping malls, hotel, restaurants and other public places. It can be efficiently used with connection to ducts for air supply, perfectly keeping the indoor air clean and fresh.

HEPA-filter can remove 95% fine particles PM2.5

超薄型静音管道风机是现代居住场所必备的通风设备，它能有效地进行送风，令室内空气清新、干净，适用于家庭、别墅、办公楼、会议室、商场、宾馆、酒楼或其它公共场所等。

采用高效过滤网，能去除95%的微细悬浮粒子PM2.5。

### External Dimensions 外形尺寸图

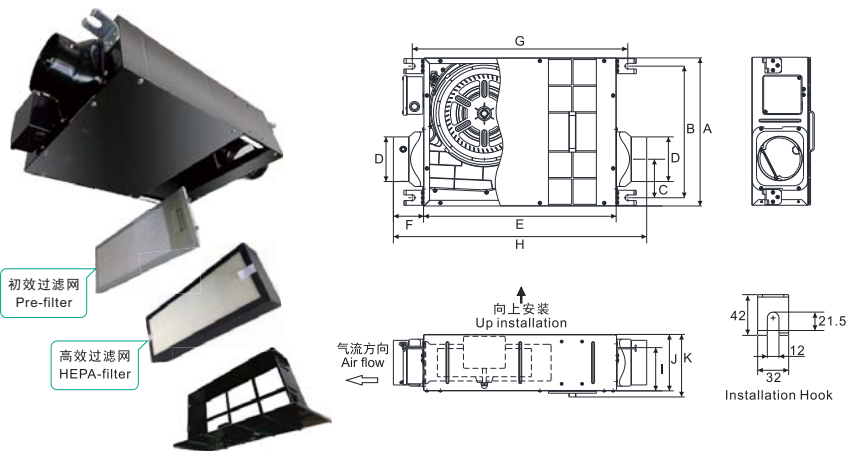

### Dimension Table 尺寸表

Units 单位:mm

型号 Model No.	A	B	C	D	E	F	G	H	I	J	K	管口尺寸 Duct Size (mm)
DGT10-24H	315	280	100	95	410	65	459	540	92	120	133	Φ100
DGT15-34H	315	280	120	148	410	65	459	540	132	170	183	Φ150
DGT15-45H	362	327	126	148	460	65	509	590	107	170	183	Φ150

## Super-Slim Type Low-Noise Duct Fan (With Filter)

### 超薄型静音管道风机 (带过滤网)

### Electrical Ratings 技术参数

型号 Model No.	额定电压/ 频率/ 相数 Rated Voltage/ Frequency/ Phase	风轮直径 Impeller Diameter (mm)	档位 Setting	功率 Power (W)	转速 Rotating Speed (R.P.M.)	风量 Air Volume (m <sup>3</sup> /h)	静压 Static Pressure (Pa)	噪音 Noise (dB)	电机绝缘等级 Insulation Class	净重 Net Weight (kg)	
DGT10-24H	220V~/50Hz/1Ph	200	高档 High	40	1300	150	190	24	E	5.5	
低档 Low			30	1060	120	180	21				
DGT15-34H		200	高档 High	60	1360	250	235	31		6.3	
			低档 Low	51	1190	210	225	25			
DGT15-45H		230	230	高档 High	93	1360	350	270		34	9.0
				低档 Low	72	1150	285	255		28	

### Performance Curve 性能曲线图

- A: DGT10-24H(低档 Low)      B: DGT10-24H(高档 High)  
 C: DGT15-34H(低档 Low)      D: DGT15-34H(高档 High)  
 E: DGT15-45H(低档 Low)      F: DGT15-45H(高档 High)

